

Circuit Diagram

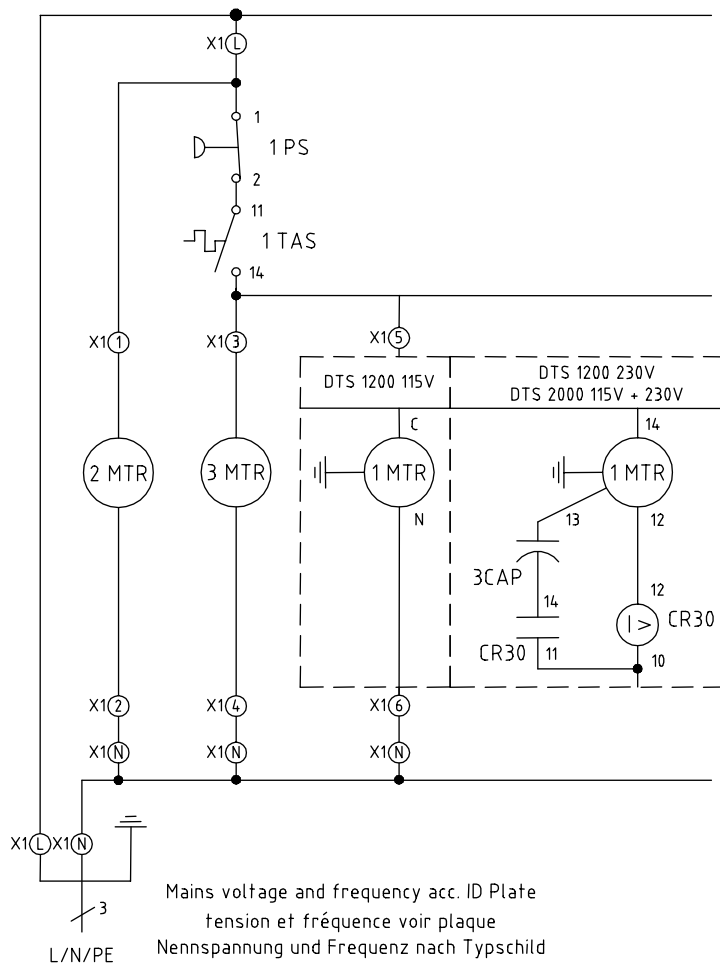

- 1 PS High-pressurestat / pressostat haute pression / Hochdruckpressostat
- 1 TAS Thermostat / thermostat / Thermostat
- CAP 3 Capacitors / condensateurs / Betriebskondensatoren
- CR 30 Start-relay compressor / relais de départ du compresseur / Anlaufrelais Verdichter
- 1 MTR Compressor / compresseur / Verdichter
- 2 MTR Evaporator fan / ventilateur de l'évaporateur / Radialventilator-Verdampfer
- 3 MTR Condenser fan / ventilateur du condenseur / Radialventilator-Verflüssiger

11189-068d

Recommended Fuse Value – 10A

Airflow Principle

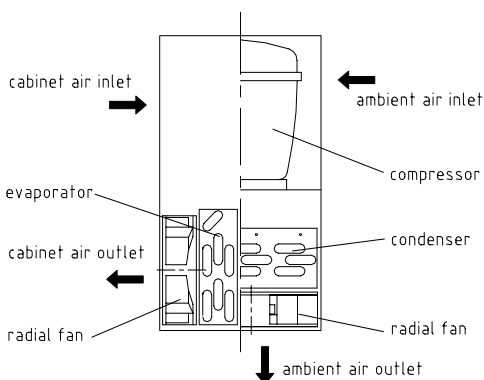

Sealings

(front view enclosure)

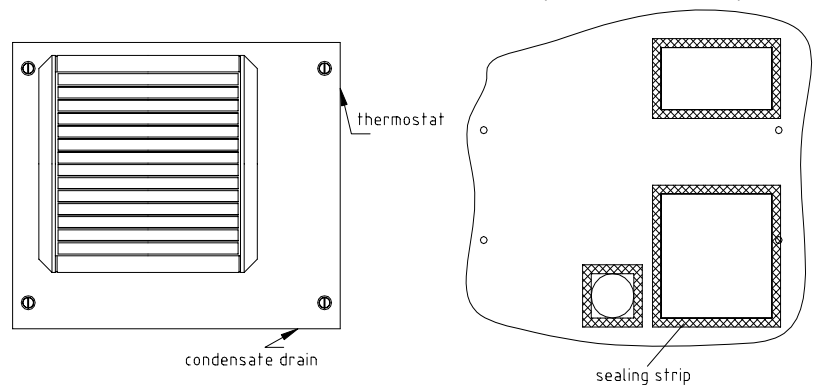

DTS 1200 – 115V

Technical Data - Series DTS 1200

Model	DTS 1200
Cooling data	
Rated capacity at ambient 24°C (A75°F) / internal 35°C (A95°F) *	350 W / 1200 BTU/h
Rated capacity at ambient 35°C (A95°F) / internal 35°C (A95°F)	150 W / 520 BTU/h
Refrigerant type *	R 134a
Refrigerant charge *	280 g / 10 oz
Adjustable thermostat setting (factory set)	+35°C / +95°F
Permissible min./max. ambient air temperature	+8°C to +52°C / +46°F to +125°F
Air volume unrestricted, external circulation	390 m³/h / 230 ft³/min
Air volume unrestricted, internal circulation	180 m³/h / 106 ft³/min
Condensate discharge	direct via tube
Noise level (1m / 3.29 ft distance)	≤ 62 dB(A)
Electrical data	
Rated voltage *	115 V
Mains frequency *	60 Hz
Operating range (IEC 60038)	103 V...127 V
Power consumption *	200 W
Nominal current *	2,2 A
Starting current *	15,7 A
Line cord	3 prong N/A plug (ca. 2m / 6.59ft)
EMI/RFI suppression	CE
Dimensions	
Height	330 mm / 13 inch
Width	375 mm /14.76 inch
Depth	190 mm / 7.48 inch
Weight	18 kg / 40 lb
Unit orientation for installation and storage	vertical
Exterior case construction	sheet steel
Corrosion protection	galvanized, electrostatically powder coated: RAL 7032, BAKE (200°C / 392°F) ANSI 61, BAKE (163°C / 325°F)
Protection classification	IP 54 against the enclosure (EN 60529), under correct operating conditions IP 34 against the environment (EN 60529), under correct operating conditions

* ID Plate Information

Spare parts / Accessories

Please order your spare parts only with the *Pfannenber*g-parts-number.

Internal fan	010 041 510
External fan	010 041 580
Thermostat	030 600 207
Filtermat	015 053 040
Replacement Grill	015 065 040